

# ASSEMBLY INSTRUCTION

## I. Notice of assembly

- \* An enough dimension will be required to assemble and properly use the machine.
- \* Please use floor padding, such as cardboard, to avoid scratching your floor during assembly.
- \* The nuts and bolts have a little grease on them to protect them from corrosion. Please keep a rag handy to wipe your hands.
- \* All plastic end caps and plugs have been assembled on the unit prior to shipment. They are shown on the assembly drawings for reference in the event replacement parts are needed.
- \* The machine uses several different lengths of bolts. Be careful to use the correct length of bolt called for at each step of assembly.

## II. Before you begin

1. Locate a comfortable work site. Assemble your machine in an open space with ventilation and lighting, and with the help of other person. The machine poses a large area, so you do not place it in living room.
2. Find your tools. You will need the following tools to assemble your machine.
  - . Ruler with both metric and English measurements
  - . Adjustable wrench
  - . WD40 lubricant or Vaseline (if necessary)

## III. Assembling your machine

## EXPLODED DRAWING

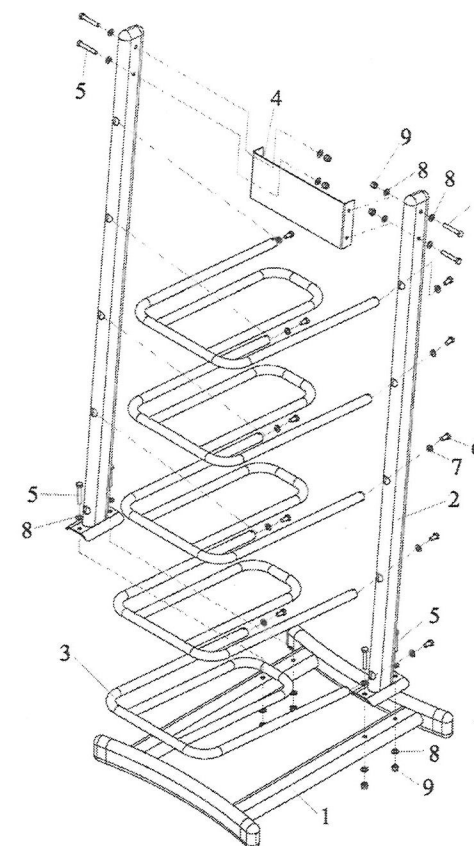

NUMBER	DESCRIPTION	QUANTITY
1	BASE FRAME	1
2	UPRIGHT TUBE	2
3	SUPPORT	5
4	LOGO PLATE	1
5	BOLT M10*60	8
6	BOLT M10*30	10
7	BEND WASHER 10	10
8	WASHER 10	16
9	LOCK NUT M10	8